

High Productivity Cooking Electric Tilting Braising Pan, 80lt, Hygienic Profile, Freestanding

ITEM # _____

MODEL # _____

NAME # _____

SIS # _____

AIA # _____

586281 (PFET08ECE0)

 Electric tilting Braising Pan
 80lt (h), with compound
 bottom, GuideYou panel,
 freestanding

Short Form Specification

Item No. _____

AISI 304 stainless steel construction. Pan in AISI 304 stainless steel; 18mm thick pan bottom (15mm mild steel and 3 mm AISI 316 stainless steel). Insulated and counterbalanced lid. Motorized tilting with variable speed control. Pan can be tilted beyond 90° to completely empty the food. The electric heating elements are mounted under the well. Safety thermostat protects the pan from overheating. A precise, electronic control of pan bottom temperature ensures fast reaction and exact adherence to preselected cooking temperatures between 50° and 250°C. TOUCH control panel. SOFT function. Possibility to store recipes in single or multiphase cooking process, with different temperature settings. Built in temperature sensors for precise control of cooking process. IPX6 water resistant. Configuration: Free-standing or Standing against a wall. Installation options (not included): floor mounted on 200mm high feet or a plinth which can be either steel or masonry construction.

Main Features

- Easy to clean cooking surface due to large-radius edges and corners.
- Thermoblock heating system for optimal temperature distribution and high temperature stability.
- Pan bottom with two individually adjustable heating zones, each with a temperature sensor.
- IPX6 water resistant.
- Temperature sensors provides efficient temperature control: the power is supplied as and when required to keep the set temperature value without exceeding it.
- Optimum heat distribution in the food provides best cooking results in terms of taste, colour and consistency and in terms of vitamin preserving.
- Motorized, variable pan tilting with "SOFT STOP". Tilting and pouring speeds can be precisely adjusted. Pan can be tilted over 90° to facilitate pouring and cleaning operations.
- Built in temperature sensor to precisely control the cooking process.
- No overshooting of cooking temperatures, fast reaction.
- USB connection to easily update the software, upload/download recipes and download HACCP data.
- Multifunctional cooking appliance used for roasting, pot-roasting, braising, simmering, boiling and steaming.

APPROVAL: _____

Construction

- External panelling and internal frame made of 1.4301 (AISI 304) stainless steel.
- Multipurpose non-stick cooking surface in 18 mm thick compound: 3 mm shot-blasted 1.4404 (AISI 316L) stainless steel surface, seamlessly welded to the mild steel bottom.
- Double-lined insulated lid in 1.4301 (AISI 304) stainless steel mounted on the cross beam of the unit, counterbalanced by a hinge that remains open in all positions.
- 15 mm thick heating layer concealed below the entire pan bottom, to provide high thermal diffusion and heat storage properties.
- Water mixing tap is available as optional accessory to make water filling and pan cleaning easier.
- Heatproof handle with non-slip surface.
- Front-mounted inclined led "TOUCH" control panel with recessed deep drawn casing, features self-explanatory display functions which guide operator throughout the cooking process: simultaneous display of actual and set temperature as well as set cooking time and remaining cooking time; real time clock; "SOFT" control for gentle heating up for delicate food; 9 power simmering levels from gentle to heavy boiling; timer for deferred start; error display for quick troubleshooting.
- Possibility to store recipes in single or multiphase cooking process, with different temperature settings.
- Can be prearranged for energy optimisation or external surveillance systems (optional).
- 98% recyclable by weight; packaging material free of toxic substances.
- Lateral surface of the vessel in DIN 1.4301/AISI 304.

User Interface & Data Management

- Connectivity ready for real time access to connected appliances from remote and data monitoring (requires optional accessory - contact the Company for more details).

Sustainability



- High-quality thermal insulation of the pan saves energy and keeps operating ambient temperature low.

Optional Accessories

- | | | |
|--|------------|--------------------------|
| • Strainer for dumplings for 100lt boiling pans | PNC 910054 | <input type="checkbox"/> |
| • Scraper for dumpling strainer for boiling and braising pans | PNC 910058 | <input type="checkbox"/> |
| • Stainless steel plinth for tilting units - against wall - factory fitted | PNC 911425 | <input type="checkbox"/> |
| • Stainless steel plinth for tilting units - freestanding - factory fitted | PNC 911455 | <input type="checkbox"/> |
| • Small perforated shovel for braising pans (PFEN/PUEN) | PNC 911577 | <input type="checkbox"/> |
| • Small shovel for braising pans (PFEN/PUEN) | PNC 911578 | <input type="checkbox"/> |
| • Bottom plate with 2 feet, 200mm for tilting units (height 700mm) - factory fitted | PNC 911930 | <input type="checkbox"/> |
| • C-board (length 1400mm) for tilting units - factory fitted | PNC 912186 | <input type="checkbox"/> |
| • MOBILE KIT TxxT/PxxT (VAR.width=S-Code) | PNC 912460 | <input type="checkbox"/> |
| • Power Socket, CEE16, built-in, 16A/400V, IP67, red-white - factory fitted | PNC 912468 | <input type="checkbox"/> |
| • Power Socket, CEE32, built-in, 32A/400V, IP67, red-white - factory fitted | PNC 912469 | <input type="checkbox"/> |
| • Power Socket, SCHUKO, built-in, 16A/230V, IP68, blue-white - factory fitted | PNC 912470 | <input type="checkbox"/> |
| • Power Socket, TYP23, built-in, 16A/230V, IP55, black - factory fitted | PNC 912471 | <input type="checkbox"/> |
| • Power Socket, TYP25, built-in, 16A/400V, IP55, black - factory fitted | PNC 912472 | <input type="checkbox"/> |
| • Power Socket, SCHUKO, built-in, 16A/230V, IP55, black - factory fitted | PNC 912473 | <input type="checkbox"/> |
| • Power Socket, CEE16, built-in, 16A/230V, IP67, blue-white - factory fitted | PNC 912474 | <input type="checkbox"/> |
| • Power Socket, TYP23, built-in, 16A/230V, IP54, blue - factory fitted | PNC 912475 | <input type="checkbox"/> |
| • Power Socket, SCHUKO, built-in, 16A/230V, IP54, blue - factory fitted | PNC 912476 | <input type="checkbox"/> |
| • Power Socket, TYP25, built-in, 16A/400V, IP54, red-white - factory fitted | PNC 912477 | <input type="checkbox"/> |
| • Panelling for plinth recess (depth from 70 to 270mm) for tilting units - factory fitted (Deutschland, Austria, Switzerland) - factory fitted | PNC 912479 | <input type="checkbox"/> |
| • Connecting rail kit for appliances with backsplash, 900mm | PNC 912499 | <input type="checkbox"/> |
| • Connecting rail kit, 900mm | PNC 912502 | <input type="checkbox"/> |
| • Rear closing kit for tilting units - against wall - factory fitted | PNC 912706 | <input type="checkbox"/> |
| • Automatic water filling (hot and cold) for tilting units - to be ordered with water mixer - factory fitted | PNC 912735 | <input type="checkbox"/> |

Front

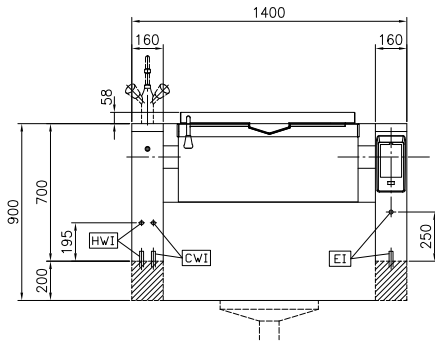

Side

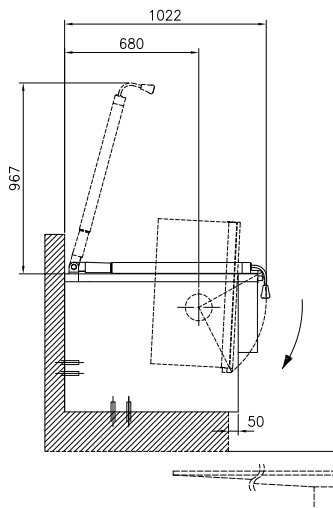

CWI = Cold Water inlet 1 (cleaning)
 EI = Electrical inlet (power)
 HWI = Hot water inlet

Top

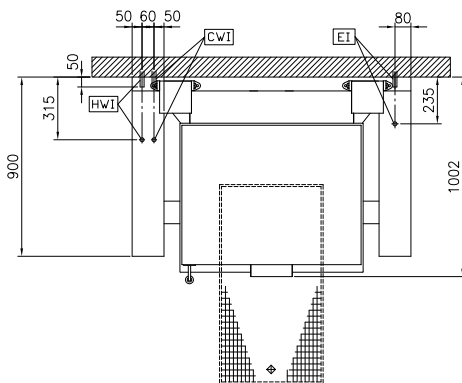

Electric

Supply voltage: 400 V/3N ph/50/60 Hz
 Total Watts: 20.6 kW

Installation:

Type of installation: On Base

Key Information:

Working Temperature MIN: 50 °C
 Working Temperature MAX: 250 °C
 Vessel (rectangle) width: 820 mm
 Vessel (rectangle) height: 200 mm
 Vessel (rectangle) depth: 638 mm
 External dimensions, Width: 1400 mm
 External dimensions, Depth: 900 mm
 External dimensions, Height: 700 mm
 Net weight: 240 kg
 Configuration: Rectangular; Tilting
 Net vessel useful capacity: 58 lt
 Tilting mechanism: Automatic
 Double jacketed lid: ✓
 Heating type: Direct